

Backbone Transportation Service Open Season 2026

**To join audio only for the webinar,
use the following dial-in number and Conference ID.**

Dial-In Number: (858) 284-1506

Conference ID: 102 952 577#



Backbone Transportation Service Open Season

2026



Glad to be of service.®

Antitrust Disclaimer

AMERICAN GAS ASSOCIATION ANTITRUST COMPLIANCE GUIDELINES

Introduction

The American Gas Association and its member companies are committed to full compliance with all laws and regulations, and to maintaining the highest ethical standards in the way we conduct our operations and activities. Our commitment includes strict compliance with federal and state antitrust laws, which are designed to protect this country's free competitive economy.

Responsibility for Antitrust Compliance

Compliance with the antitrust laws is a serious business. Antitrust violations may result in heavy fines for corporations, and in fines and even imprisonment for individuals. While the General Counsel's Office provides guidance on antitrust matters, you bear the ultimate responsibility for assuring that your actions and the actions of any of those under your direction comply with the antitrust laws.

Antitrust Guidelines

In all AGA operations and activities, you must avoid any discussions or conduct that might violate the antitrust laws or even raise an appearance of impropriety. The following guidelines will help you do that:

- **Do** consult counsel about any documents that touch on sensitive antitrust subjects such as pricing, market allocations, refusals to deal with any company, and the like.
- **Do** consult with counsel on any non-routine correspondence that requests an AGA member company to participate in projects or programs, submit data for such activities, or otherwise join other member companies in AGA actions.
- **Do** use an agenda and take accurate minutes at every meeting. Have counsel review the agenda and minutes before they are put into final form and circulated and request counsel to attend meetings where sensitive antitrust subjects may arise.
- **Do** provide these guidelines to all meeting participants.

- **Do not, without prior review by counsel,** have discussions with other member companies about:

- ♦ your company's prices for products, assets or services, or prices charged by your competitors
 - ♦ costs, discounts, terms of sale, profit margins or anything else that might affect those prices
 - ♦ the resale prices your customers should charge for products or assets you sell them
 - ♦ allocating markets, customers, territories products or assets with your competitors
 - ♦ limiting production
 - ♦ whether or not to deal with any other company
 - ♦ any competitively sensitive information concerning your own company or a competitor's.
- **Do not** stay at a meeting, or any other gathering, if those kinds of discussions are taking place.
 - **Do not** discuss any other sensitive antitrust subjects (such as price discrimination, reciprocal dealing, or exclusive dealing agreements) without first consulting counsel.
 - **Do not** create any documents or other records that might be misinterpreted to suggest that AGA condones or is involved in anticompetitive behavior.

We're Here to Help

Whenever you have any question about whether particular AGA activities might raise antitrust concerns, contact the General Counsel's Office, Ph: (202) 824-7072; E-mail: GCO@aga.org, or your legal counsel.

American Gas Association
Office of General Counsel
Issued: December 1997
Revised: December 2008

What's New?

- **BTS2 rate design changed back to Modified Fixed Variable effective October 1, 2026**
- **New BTS5 volumetric rate option also effective October 1, 2026**
- **One-time 37-month term for this open season to put subsequent BTS terms on a November 1 cycle**
- **Revised Step 1 Set Aside bidding rights for Rule 39 Displacement Capacity receipt points**

What is Backbone Transportation Service?

Backbone Transportation Service (BTS) provides firm and interruptible access to the SoCalGas® and San Diego Gas & Electric® (SDG&E®) integrated natural gas transmission system.

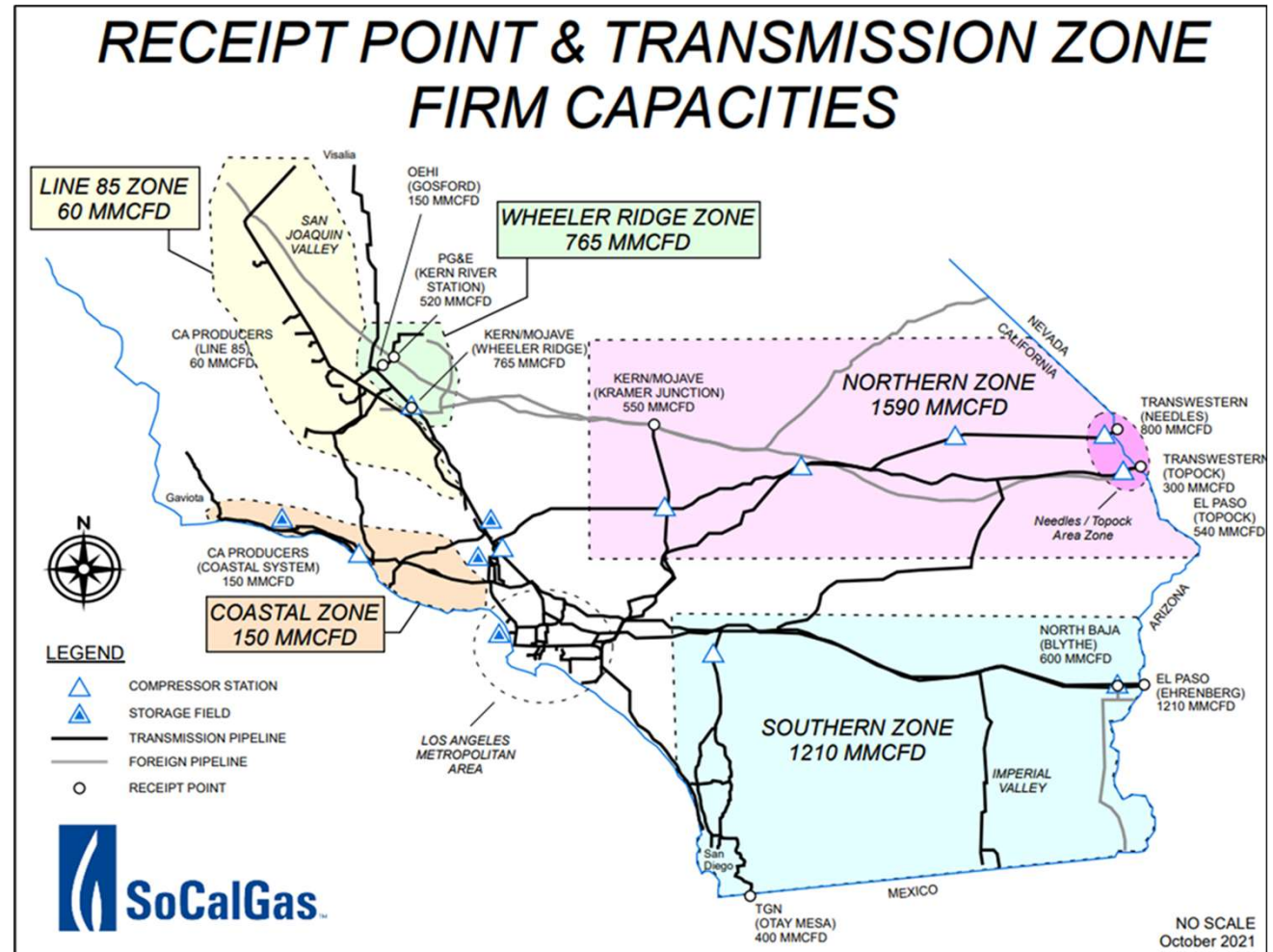

What is the Open Season?

A three-step process defined in SoCalGas Rate Schedule No. G-BTS for customers to bid for firm BTS rights for specified contract terms through an online bidding system.

Maintenance Reductions (Posted Outages)

Available BTS capacity is limited by receipt point, Sub-Zone, Area Zone, and Transmission Zone constraints.

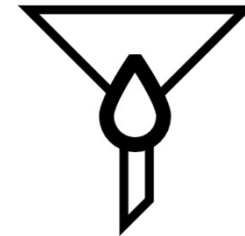

BTS capacity will not be offered if the capacity reduction is expected to extend for a period of one month or more during the BTS Open Season term.



Out of service BTS capacity with a defined End Date will be offered if the End Date is prior to November 1, 2026.



Maintenance Reductions (Impact on Awarded BTS)

Awarded BTS capacity affected by posted outages during the Open Season process may be exchanged for capacity at other Receipt Points if capacity is available at those points during the Recontracting Step.

Awarded BTS capacity affected by posted outages that is not recontracted will be removed from participant's awarded capacity for the period that the capacity is impacted.

Awards subject to recall that are not recontracted will be recalled in the following manner: Step 3 awards, Step 2 awards, Step 1 awards.

Maintenance Reductions past October 31, 2026

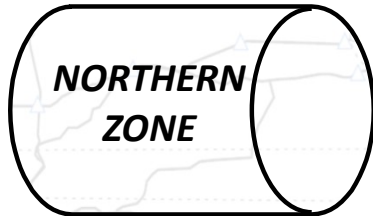

**Topock Sub-Zone constraint
(190 MMcfd reduction)**

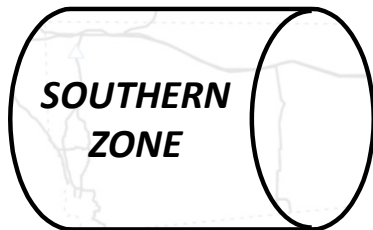

**Southern Zone constraint (seasonal load
conditions) (560 MMcfd reduction)**

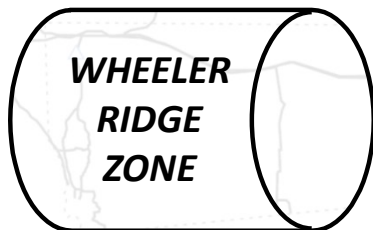

**No Wheeler Ridge Zone constraint (current
outage scheduled to end August 1)**

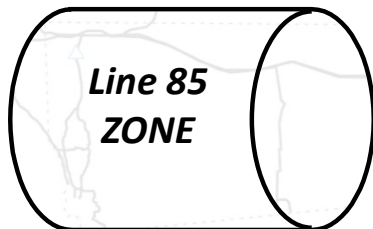

Line 85 Zone constraint (20 MMcfd reduction)

Open Season 2026 Capacity Offering*

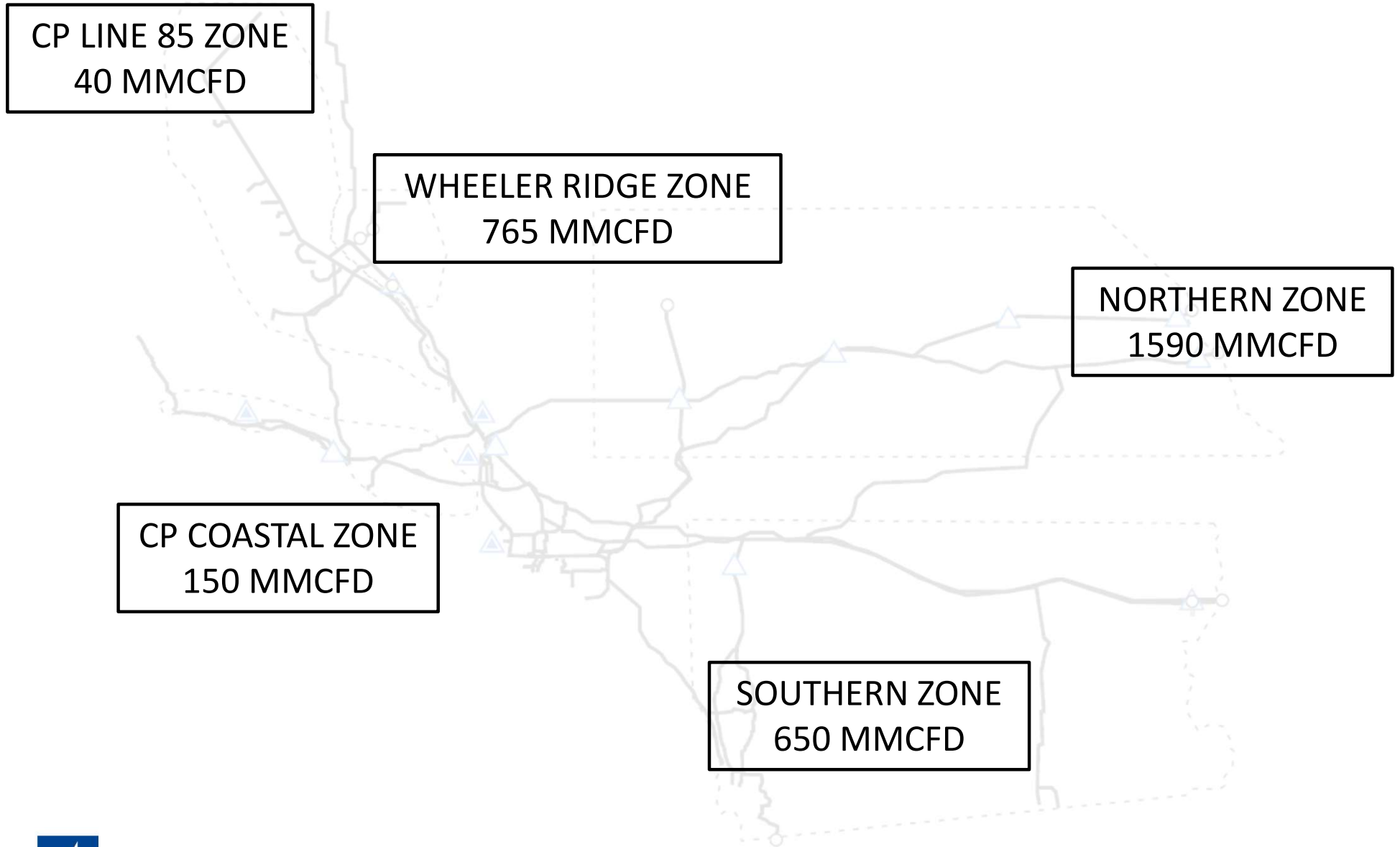

*Subject to change. Contingent on maintenance reductions.

Glad to be of service.®

Open Season 2026 Capacity Offering*

	<u>2023</u>	<u>2026</u>
SOUTHERN ZONE	750 MMCFD	650 MMCFD
NORTHERN ZONE	990 MMCFD	1590 MMCFD
WHEELER RIDGE ZONE	765 MMCFD	765 MMCFD
CP LINE 85 ZONE	60 MMCFD	40 MMCFD
CP COASTAL ZONE	150 MMCFD	150 MMCFD
TOTAL	2,715 MMCFD	3,195 MMCFD



*Subject to change. Contingent on maintenance reductions.

Glad to be of service.®

How to Register for the Open Season

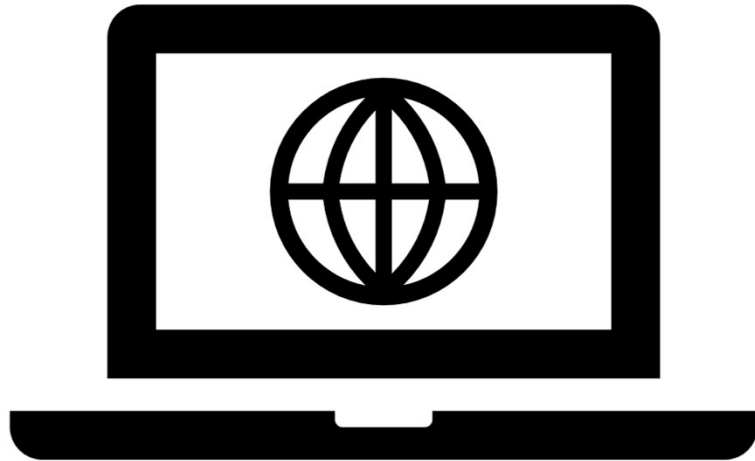

SoCalGas will make the Open Season online bidding system available May 2026. You may register to become an authorized bidder through the bidding system once the website is made available.

How to Register for the Open Season

To register for the bidding system, you must have the following:

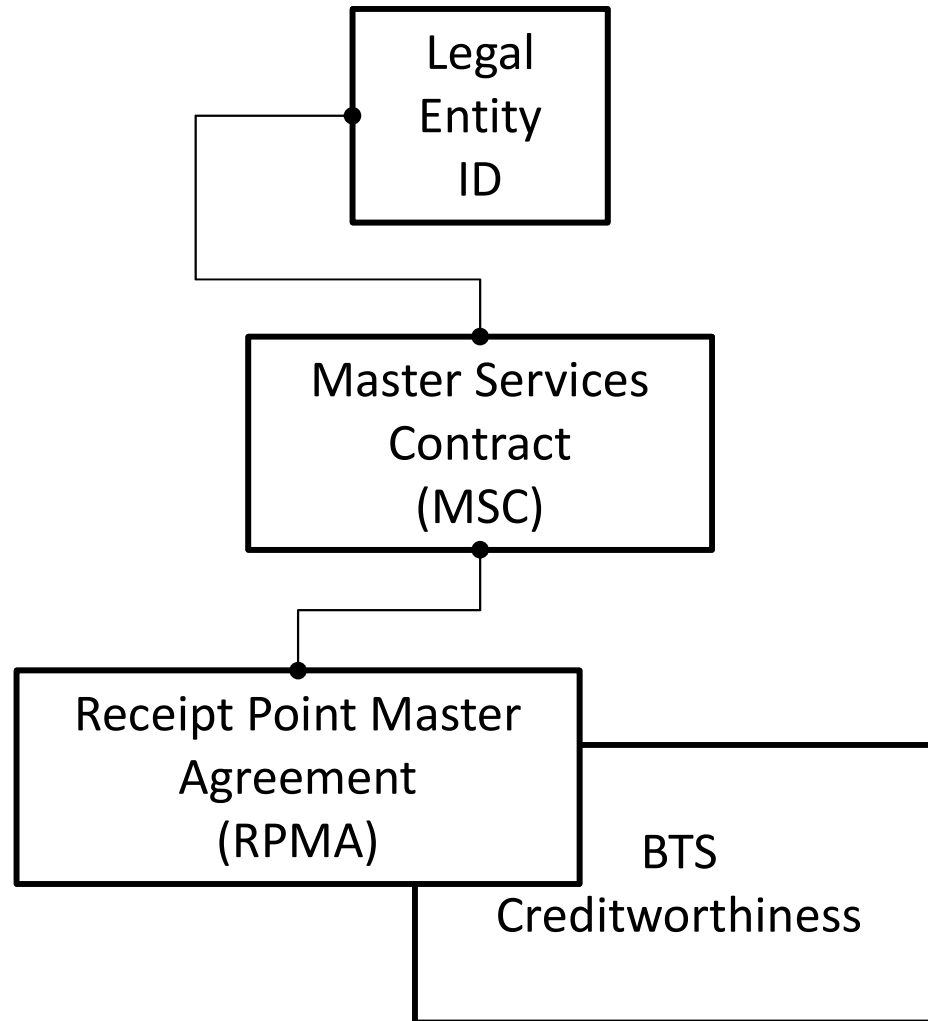

Open Season High-Level Process Summary

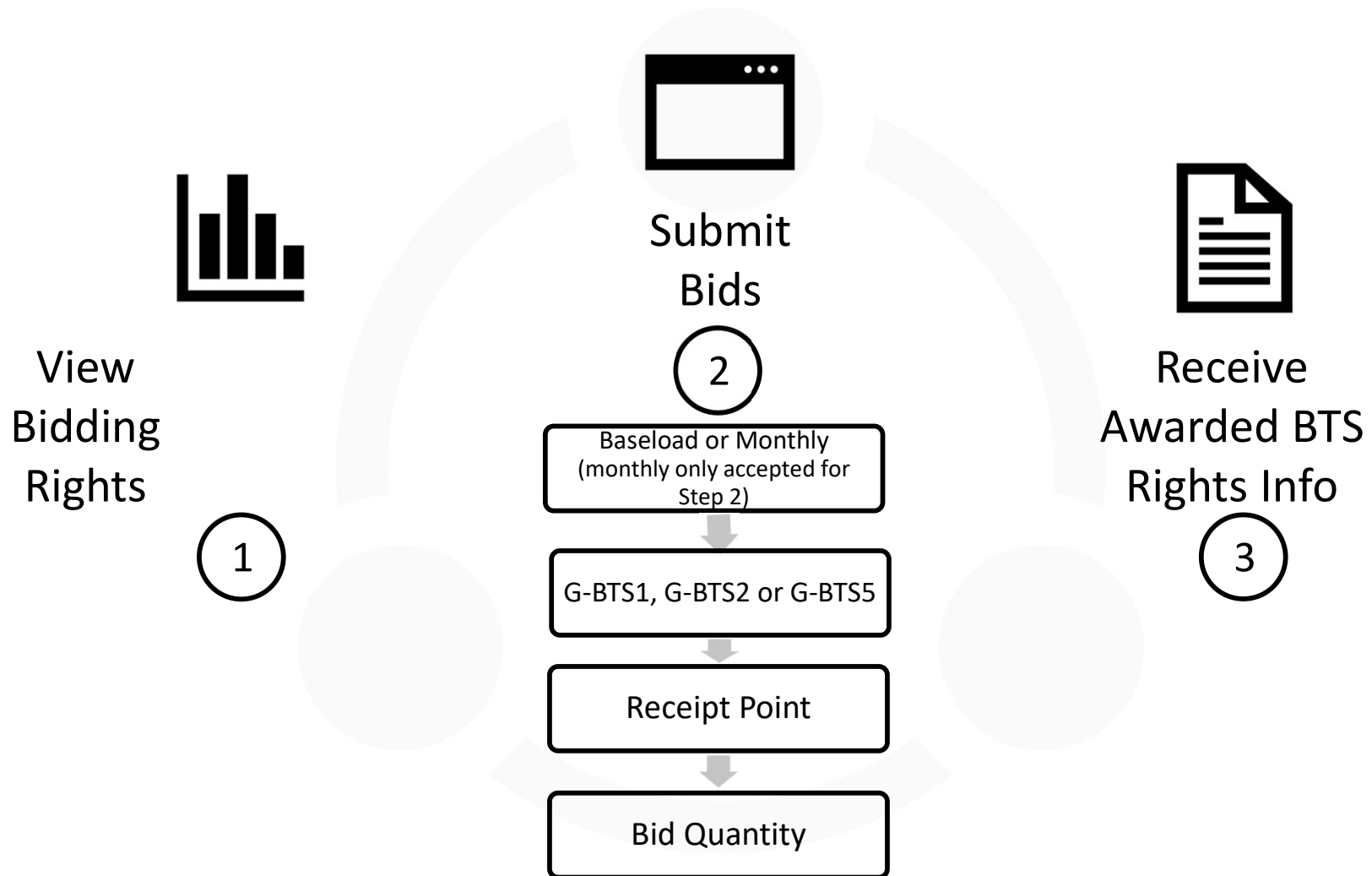

Open Season Summary of Steps

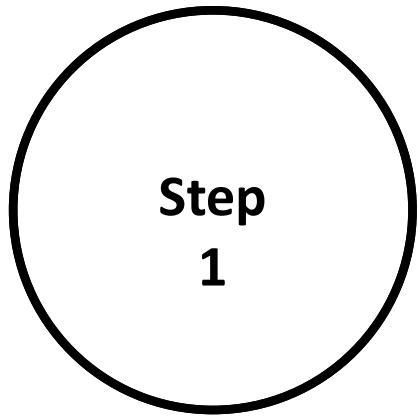

**Pre-Open Season
Set-Asides**

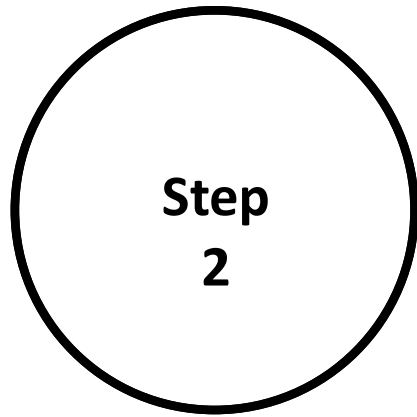

**Preferential
Bidding
(3 Rounds)**

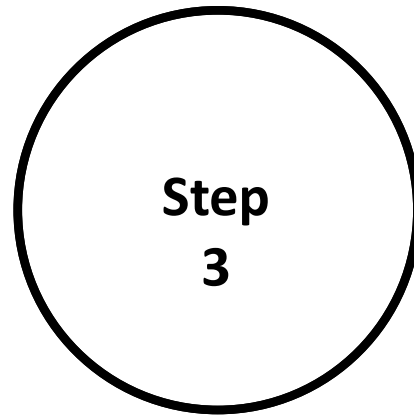

**Non-Preferential
Bidding**

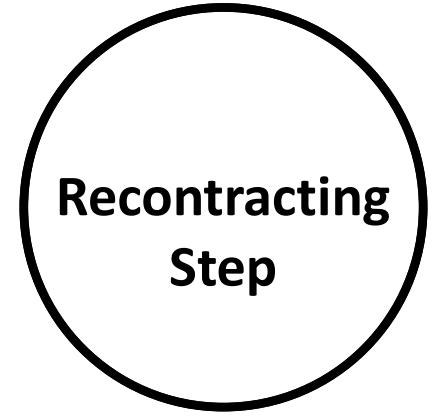

**Exchange Rights
to Different
Receipt Point(s)**

Open Season Calendar

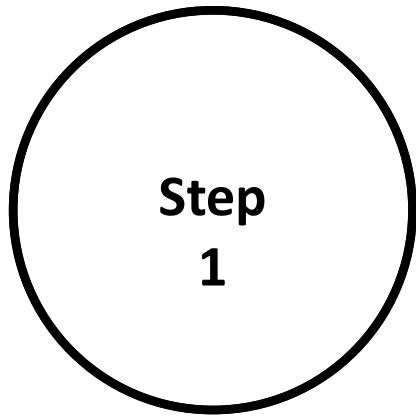

Jun 8 - Jun 11

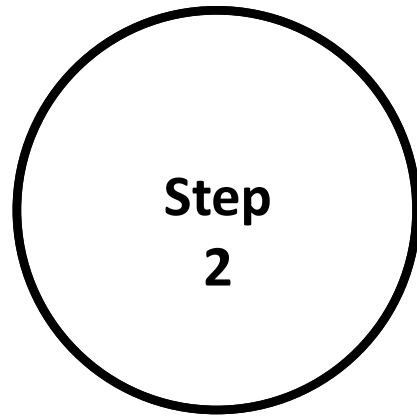

Aug 11 - Aug 27

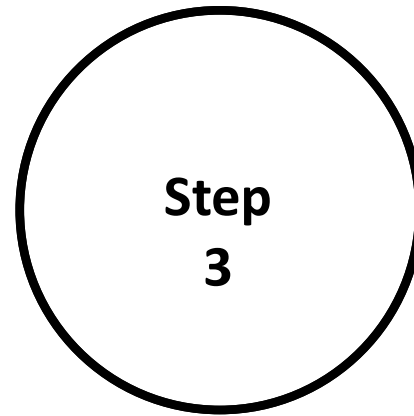

Sep 1 – Sep 3

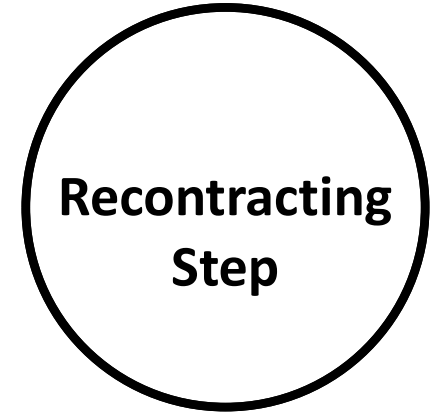

Sep 8- Sept 11

Open Season Lengths of BTS Contract Terms

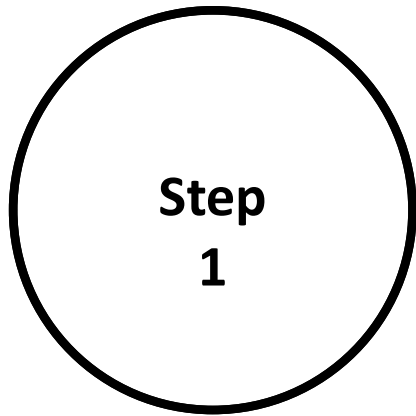

**3-Year, 1-month
Terms
(2026 - 2029)**

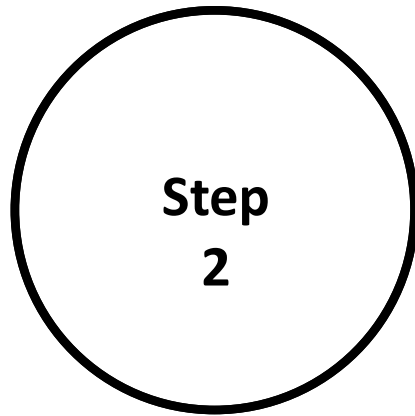

**3-Year, 1-month
Terms
(2026 - 2029)**

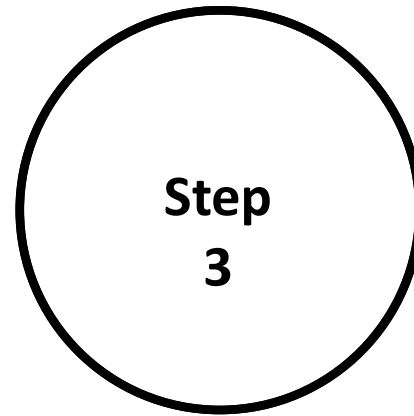

**3-Year, 1-month
to 20-Year Terms
(2026 - 2046)**

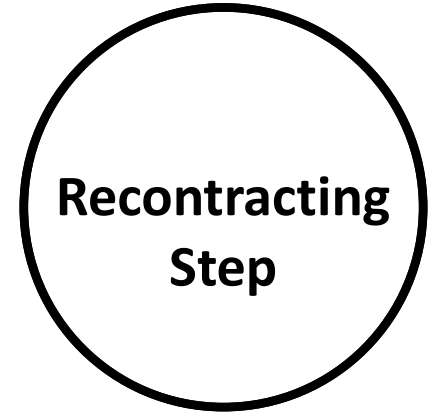

**3-Year, 1-month
Terms
(2026 - 2029)**

Open Season Bid Evaluations

Bids for baseload capacity have higher priority than bids for monthly capacity

If more quantity is bid for at a particular receipt point than is available, all bidders will be awarded rights on a pro-rata basis to the amount they bid for at that particular receipt point.

Bids will be prorated first at a particular Receipt Point, then the Sub-Zone, then the Area Zone, and then at the Transmission Zone if needed.

Successful bidders are contractually liable for all awarded firm BTS rights.

Pre-Open Season

Step 1

Who Can Participate?

Utility Gas Procurement Department, Wholesale Customers (core loads only), Core Transport Agents, California Producers, PG&E G-XF Contracts, Parties that fund increased receipt point capacity either on displacement basis or expansion basis under Rule No. 39.

What Type of Bids Can I Submit?

Annual baseload bids only.



Pre-Open Season

Step 1

How are my set-asides determined?

Core Balancing Agents: based on qualifying upstream transportation agreements with a minimum term of 12 months that are in effect 2 months prior to the beginning of the Open Season term.

CA Producers: based on peak month's daily average production over the most recent three-year period. A peak month is the month with the highest average daily volume.

PG&E G-XF Customers with effective Commission-approved contracts for delivery at PG&E Kern River Station: based on access rights at PG&E Kern River Station.

Rule 39 Receipt Point shippers who fund displacement capacity are limited to 5-years from the completion date after which set-asides will be based peak month's average daily delivery.



Open Season Step 2

Who Can Participate?

Noncore end-use customers of wholesale customers, the Utility Gas Procurement Department, Core Transport Agents, Contracted Marketers who have automatically been assigned noncore transportation customer bidding rights, noncore transportation customers who have revoked automatic assignment of their bidding rights to their Contracted Marketers, and suppliers who have been assigned bidding rights by noncore transportation customers.

What Type of Bids Can I Submit?

Annual baseload bids and monthly bids.

Open Season Step 2

How are my bidding rights determined?

Based on your historical usage during the Base Period. The Base Period for this Open Season is January 1, 2023 through December 31, 2025.

If you have less than 36 months of historical data, then we'll use whatever is available. You will not be able to use a previous owner's usage.

Your bidding rights may be adjusted if your future consumption is expected to exceed historical usage. Work with your Account Executive for this.

If you're a new customer, you may establish bidding rights through use-or-pay obligations.



Open Season Step 2

Bidding Summary

You may submit a combination of monthly bids and baseload bids.

In aggregate, for a year, you cannot bid more than your maximum annual bidding rights.

For any given month, you cannot bid more than your maximum bidding rights established for that month.

Open Season Step 2

Bid Evaluations

Bids for baseload capacity have higher priority than bids for monthly capacity.

Bids are evaluated at the end of each round. So, there is no advantage to bidding earlier than other bidders... but don't wait till the last minute.

Open Season Step 2

Maximum Bidding Rights

Maximum Bidding Rights include a baseload maximum plus a monthly peaking maximum over a Base Period.

Baseload maximum bidding rights will be determined based on the customer's average daily historical consumption during the Base Period less any set-aside elected by the customer under an end use transportation agreement.

The months the customer uses more than its average baseload, the customer's maximum bidding rights will be set equal to its historical usage in those particular months during the Base Period less any Step 1 set-aside elected.



Open Season Step 2: Wholesale Customers

Wholesale Customer Options for Core Customers

Wholesale customer core loads are provided base load maximum bidding rights equal to their average daily usage during the Base Period less any set aside awarded in Step 1.

Wholesale Customer Option for Noncore Customers

Wholesale customers may elect to have their noncore customers participate directly in Open Season in the same manner as all SoCalGas and SDG&E noncore customers.

Wholesale customers not electing to have their noncore customers participate directly will be provided maximum bidding rights based on their noncore customers aggregated usage during the Base Period.

Open Season Step 2: Assignment and/or Revocation of BTS Open Season Step 2 Bidding Rights

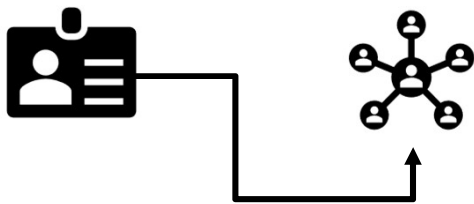

Noncore customers' bidding rights will be automatically assigned to their respective Contracted Marketers 60 days prior to the start of Step 2 unless the assignment is revoked by customer.

If a noncore customer revokes the automatic assignment of their bidding rights: (a) Noncore customer may assign bidding rights to an alternate supplier at least 60 days prior to the start of Step 2 or (b) Noncore customer may keep their own bidding rights.

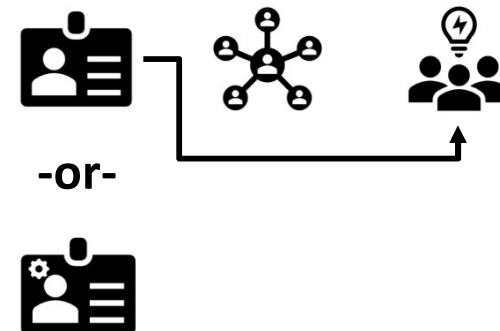

Open Season Step 3

Who Can Participate?

Any creditworthy party with an active RPMA.

What Type of Bids Can I Submit?

Annual baseload bids only.

Details:

You can bid for BTS capacity with term lengths ranging from 3-year, 1-month terms up to 20-year terms. However, if BTS capacity is unavailable for years 1 through 3 (2026 through 2029), you cannot bid for BTS capacity for years 4 through 20 (2030 through 2046).

When you submit a bid, you may select proration or no proration (all or nothing).



Open Season Recontracting Step

Who Can Participate?

Any party with awarded BTS capacity from Steps 1, 2, or 3.

What Type of Bids Can I Submit?

Any quantity of awarded capacity can be recontracted/exchanged to another receipt point to the extent it is available.

Details:

You can attempt to exchange any previously awarded capacity at a receipt point with any remaining capacity at other receipt points after Step 3.

You can submit a recontract bid for any term between October 1, 2026 and October 31, 2029.

When you submit a recontract bid, you may select proration or no proration (all or nothing).



After the Open Season

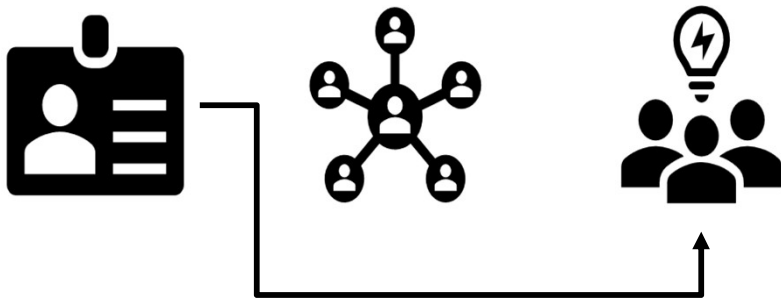

A customer may designate their Contracted Marketer or a third party agent to nominate or trade BTS on their behalf (see: *Nomination and Trading Authorization Form*)

After the Open Season

If available...

You can buy firm rights or interruptible rights on SoCalGas' EBB, SoCalGas Envoy[®], for any term with an end date not to exceed October 31, 2029.



After the Open Season



You can sell or trade BTS contracts via SoCalGas Envoy[®] after the Open Season. Max rate for sale of BTS is 125% of the applicable G-BTS1, G-BTS2 reservation rate.

Max rate for sale of G-BTS5 is zero cents.



Reminder: you are not bidding to lock in BTS rates during the Open Season. BTS Rates will vary based on the effective tariff rate at time of service.

The BTS rate is subject to California Public Utilities Commission (CPUC) approved changes during the BTS term. Customers are not allowed to return BTS capacity to SoCalGas prior to the contract expiration date.

THANK
YOU!
